



MICROCHIP

24AA256/24LC256/24FC256

256K I²C™ CMOS Serial EEPROM

Features

- Low power CMOS technology
 - Maximum write current 3 mA at 5.5 V
 - Maximum read current 400 µA at 5.5 V
 - Standby current 100 nA typical at 5.5 V
- 2-wire serial interface bus, I²C compatible
- Cascadable for up to eight devices
- Self-timed ERASE/WRITE cycle
- 64-byte page-write mode available
- 5 ms max write-cycle time
- Hardware write protect for entire array
- Output slope control to eliminate ground bounce
- Schmitt trigger inputs for noise suppression
- 1,000,000 erase/write cycles
- Electrostatic discharge protection > 4000 V
- Data retention > 200 years
- 8-pin PDIP, SOIC, TSSOP, MSOP, and DFN packages
- 14-lead TSSOP package
- Temperature ranges:
 - Industrial (I): -40°C to +85°C
 - Automotive (E): -40°C to +125°C

Description

The Microchip Technology Inc. 24AA256/24LC256/24FC256 (24XX256*) is a 32K x 8 (256 Kbit) Serial Electrically Erasable PROM, capable of operation across a broad voltage range (1.8 V to 5.5 V). It has been developed for advanced, low power applications such as personal communications or data acquisition. This device also has a page-write capability of up to 64 bytes of data. This device is capable of both random and sequential reads up to the 256K boundary. Functional address lines allow up to eight devices on the same bus, for up to 2 Mbit address space. This device is available in the standard 8-pin plastic DIP, SOIC, TSSOP, MSOP, DFN and 14-lead TSSOP packages.

Block Diagram

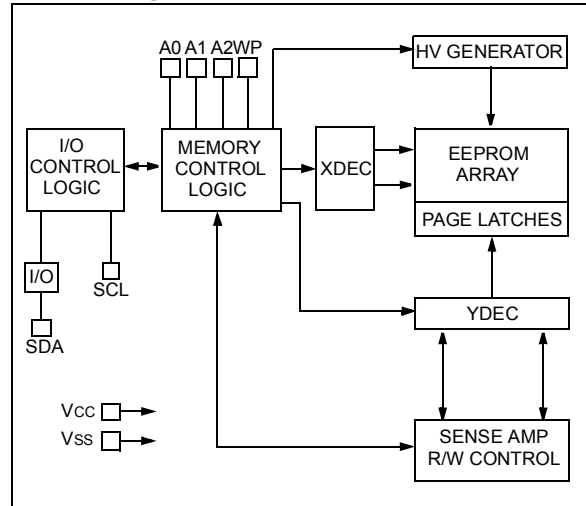

Device Selection Table

Part Number	Vcc Range	Max. Clock Frequency	Temp. Ranges
24AA256	1.8-5.5 V	400 kHz ⁽¹⁾	I
24LC256	2.5-5.5 V	400 kHz	I, E
24FC256	2.5-5.5 V	1 MHz	I

Note 1: 100 kHz for Vcc < 2.5 V.

Package Types

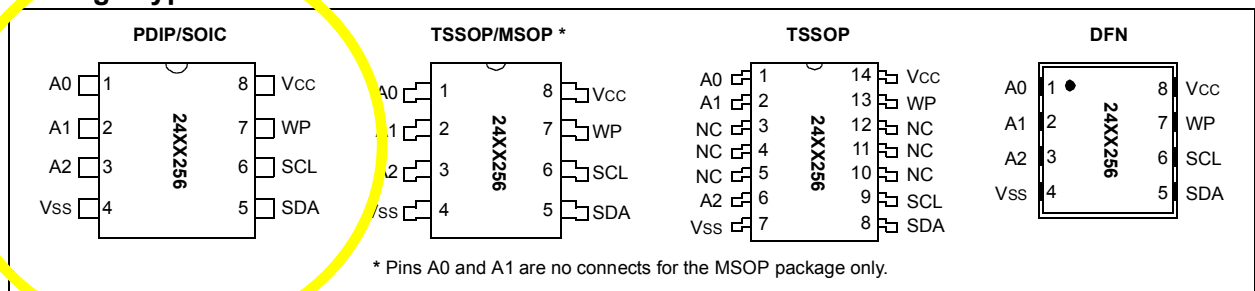

*24XX256 is used in this document as a generic part number for the 24AA256/24LC256/24FC256 devices.

24AA256/24LC256/24FC256

1.0 ELECTRICAL CHARACTERISTICS

Absolute Maximum Ratings†

V _{CC}	6.5 V
All inputs and outputs w.r.t. V _{SS}	-0.6 V to V _{CC} +1.0 V
Storage temperature	-65°C to +150°C
Ambient temp. with power applied	-65°C to +125°C
ESD protection on all pins	≥ 4 kV

† **NOTICE:** Stresses above those listed under “Maximum Ratings” may cause permanent damage to the device. This is a stress rating only and functional operation of the device at those or any other conditions above those indicated in the operational listings of this specification is not implied. Exposure to maximum rating conditions for extended periods may affect device reliability.

1.1 24AA256/24LC256/24FC256 DC Electrical Specifications

DC Specifications			Electrical Characteristics:			
			Industrial (I): V _{CC} = +1.8 V to 5.5 V T _{AMB} = -40°C to +85°C			
			Automotive (E): V _{CC} = +2.5 V to 5.5 V T _{AMB} = -40°C to +125°C			
Param. No.	Sym	Characteristic	Min	Max	Units	Conditions
D1	—	A0, A1, A2, SCL, SDA and WP pins:	—	—	—	—
D2	V _{IH}	High level input voltage	0.7 V _{CC}	—	V	—
D3	V _{IL}	Low level input voltage	—	0.3 V _{CC} 0.2 V _{CC}	V	V _{CC} ≥ 2.5 V V _{CC} < 2.5 V
D4	V _{HYS}	Hysteresis of Schmitt Trigger inputs (SDA, SCL pins)	0.05 V _{CC}	—	V	V _{CC} ≥ 2.5 V (Note)
D5	V _{OL}	Low level output voltage	—	0.40	V	I _{OL} = 3.0 ma @ V _{CC} = 4.5 V I _{OL} = 2.1 ma @ V _{CC} = 2.5 V
D6	I _{LI}	Input leakage current	—	±10	µA	V _{IN} = V _{SS} or V _{CC} , WP = V _{SS} V _{IN} = V _{SS} or V _{CC} , WP = V _{CC}
D7	I _{LO}	Output leakage current	—	±10	µA	V _{OUT} = V _{SS} or V _{CC}
D8	C _{IN} , C _{OUT}	Pin capacitance (all inputs/outputs)	—	10	pF	V _{CC} = 5.0 V (Note) T _{AMB} = 25°C, f _c = 1 MHz
D9	I _{CC} Read	Operating current	—	400	µA	V _{CC} = 5.5 V, SCL = 400 kHz
	I _{CC} Write		—	3	mA	V _{CC} = 5.5 V
D10	I _{CCS}	Standby current	—	1	µA	T _{AMB} = -40°C to +85°C SCL = SDA = V _{CC} = 5.5 V A0, A1, A2, WP = V _{SS}
			—	5	µA	T _{AMB} = -40°C to +125°C SCL = SDA = V _{CC} = 5.5 V A0, A1, A2, WP = V _{SS}

Note: This parameter is periodically sampled and not 100% tested.

24AA256/24LC256/24FC256

1.2 24AA256/24LC256/24FC256 AC Electrical Specifications

AC Specifications			Electrical Characteristics:			
			Industrial (I):	V _{CC} = +1.8 V to 5.5 V	T _{AMB} = -40°C to +85°C	
			Automotive (E):	V _{CC} = +2.5 V to 5.5 V	T _{AMB} = -40°C to +125°C	
Param. No.	Sym	Characteristic	Min	Max	Units	Conditions
1	FCLK	Clock frequency	— — —	100 400 1000	kHz	1.8 V ≤ V _{CC} < 2.5 V 2.5 V ≤ V _{CC} ≤ 5.5 V 2.5 V ≤ V _{CC} ≤ 5.5 V 24FC256
2	THIGH	Clock high time	4000 600 500	— — —	ns	1.8 V ≤ V _{CC} < 2.5 V 2.5 V ≤ V _{CC} ≤ 5.5 V 2.5 V ≤ V _{CC} ≤ 5.5 V 24FC256
3	TLOW	Clock low time	4700 1300 500	— — —	ns	1.8 V ≤ V _{CC} < 2.5 V 2.5 V ≤ V _{CC} ≤ 5.5 V 2.5 V ≤ V _{CC} ≤ 5.5 V 24FC256
4	TR	SDA and SCL rise time (Note 1)	— — —	1000 300 300	ns	1.8 V ≤ V _{CC} < 2.5 V 2.5 V ≤ V _{CC} ≤ 5.5 V 2.5 V ≤ V _{CC} ≤ 5.5 V 24FC256
5	TF	SDA and SCL fall time (Note 1)	— —	300 100	ns	All except, 24FC256 2.5 V ≤ V _{CC} ≤ 5.5 V 24FC256
6	THD:STA	START condition hold time	4000 600 250	— — —	ns	1.8 V ≤ V _{CC} < 2.5 V 2.5 V ≤ V _{CC} ≤ 5.5 V 2.5 V ≤ V _{CC} ≤ 5.5 V 24FC256
7	T _{SU} :STA	START condition setup time	4700 600 250	— — —	ns	1.8 V ≤ V _{CC} < 2.5 V 2.5 V ≤ V _{CC} ≤ 5.5 V 2.5 V ≤ V _{CC} ≤ 5.5 V 24FC256
8	THD:DAT	Data input hold time	0	—	ns	(Note 2)
9	T _{SU} :DAT	Data input setup time	250 100 100	— — —	ns	1.8 V ≤ V _{CC} < 2.5 V 2.5 V ≤ V _{CC} ≤ 5.5 V 2.5 V ≤ V _{CC} ≤ 5.5 V 24FC256
10	T _{SU} :STO	STOP condition setup time	4000 600 250	— — —	ns	1.8 V ≤ V _{CC} < 2.5 V 2.5 V ≤ V _{CC} ≤ 5.5 V 2.5 V ≤ V _{CC} ≤ 5.5 V 24FC256
11	T _{SU} :WP	WP setup time	4000 600 600	— — —	ns	1.8 V ≤ V _{CC} < 2.5 V 2.5 V ≤ V _{CC} ≤ 5.5 V 2.5 V ≤ V _{CC} ≤ 5.5 V 24FC256
12	THD:WP	WP hold time	4700 1300 1300	— — —	ns	1.8 V ≤ V _{CC} < 2.5 V 2.5 V ≤ V _{CC} ≤ 5.5 V 2.5 V ≤ V _{CC} ≤ 5.5 V 24FC256
13	TAA	Output valid from clock (Note 2)	— — —	3500 900 400	ns	1.8 V ≤ V _{CC} < 2.5 V 2.5 V ≤ V _{CC} ≤ 5.5 V 2.5 V ≤ V _{CC} ≤ 5.5 V 24FC256
14	TBUF	Bus free time: Time the bus must be free before a new transmission can start	4700 1300 500	— — —	ns	1.8 V ≤ V _{CC} < 2.5 V 2.5 V ≤ V _{CC} ≤ 5.5 V 2.5 V ≤ V _{CC} ≤ 5.5 V 24FC256
15	ToF	Output fall time from V _{IH} minimum to V _{IL} maximum C _B ≤ 100 pF	10 + 0.1C _B	250 250	ns	All except, 24FC256 (Note 1) 24FC256 (Note 1)
16	TSP	Input filter spike suppression (SDA and SCL pins)	—	50	ns	All except, 24FC256 (Notes 1 and 3)
17	TWC	Write cycle time (byte or page)	—	5	ms	—
18	—	Endurance	1,000,000	—	cycles	25°C (Note 4)

- Note**
- 1: Not 100% tested. C_B = total capacitance of one bus line in pF.
 - 2: As a transmitter, the device must provide an internal minimum delay time to bridge the undefined region (minimum 300 ns) of the falling edge of SCL to avoid unintended generation of START or STOP conditions.
 - 3: The combined T_{SP} and V_{HYS} specifications are due to new Schmitt trigger inputs, which provide improved noise spike suppression. This eliminates the need for a T_I specification for standard operation.
 - 4: This parameter is not tested but ensured by characterization. For endurance estimates in a specific application, please consult the Total Endurance Model, which can be obtained on Microchip's website: www.microchip.com.

24AA256/24LC256/24FC256

FIGURE 1-1: BUS TIMING DATA

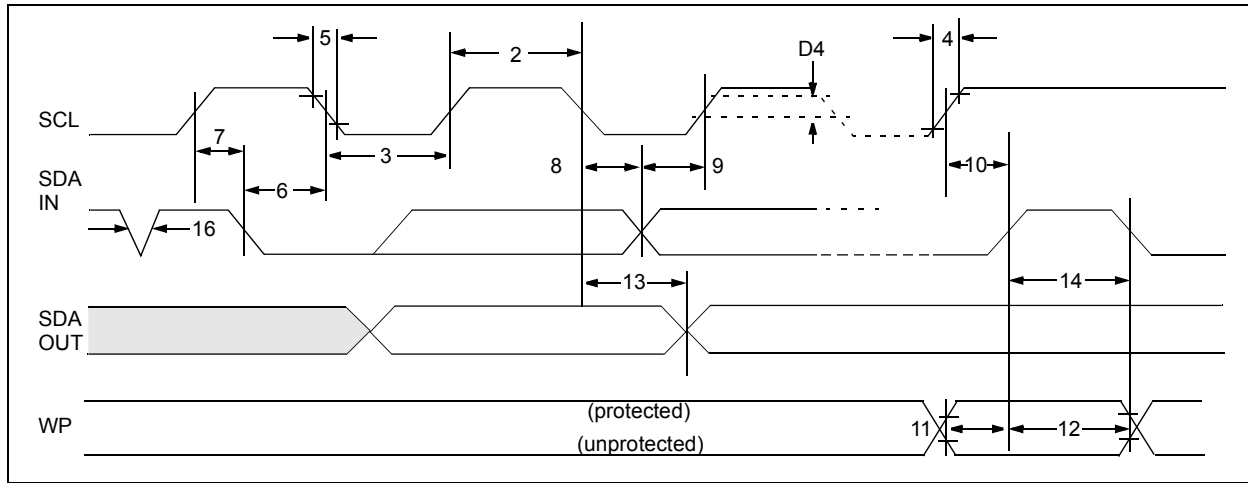

24AA256/24LC256/24FC256

2.0 PIN DESCRIPTIONS

The descriptions of the pins are listed in Table 2-1.

TABLE 2-1: PIN FUNCTION TABLE

Name	8-pin PDIP	8-pin SOIC	8-pin TSSOP	14-pin TSSOP	8-pin MSOP	8-pin DFN	Function
A0	1	1	1	1	—	1	User Configurable Chip Select
A1	2	2	2	2	—	2	User Configurable Chip Select
(NC)	—	—	—	3, 4, 5	1,2	—	Not Connected
A2	3	3	3	6	3	3	User Configurable Chip Select
Vss	4	4	4	7	4	4	Ground
SDA	5	5	5	8	5	5	Serial Data
SCL	6	6	6	9	6	6	Serial Clock
(NC)	—	—	—	10, 11, 12	—	—	Not Connected
WP	7	7	7	13	7	7	Write Protect Input
Vcc	8	8	8	14	8	8	+1.8 V to 5.5 V (24AA256) +2.5 V to 5.5 V (24LC256) +2.5 V to 5.5 V (24FC256)

2.1 A0, A1, A2 Chip Address Inputs

The A0, A1 and A2 inputs are used by the 24XX256 for multiple device operations. The levels on these inputs are compared with the corresponding bits in the slave address. The chip is selected if the compare is true.

For the MSOP package only, pins A0 and A1 are not connected.

Up to eight devices (two for the MSOP package) may be connected to the same bus by using different chip select bit combinations. If these pins are left unconnected, the inputs will be pulled down internally to Vss. If they are tied to Vcc or driven high, the internal pull-down circuitry is disabled.

In most applications, the chip address inputs A0, A1 and A2 are hard-wired to logic '0' or logic '1'. For applications in which these pins are controlled by a microcontroller or other programmable device, the chip address pins must be driven to logic '0' or logic '1' before normal device operation can proceed.

2.2 Serial Data (SDA)

This is a bi-directional pin used to transfer addresses and data into and out of the device. It is an open drain terminal. Therefore, the SDA bus requires a pull-up resistor to Vcc (typical 10 k Ω for 100 kHz, 2 k Ω for 400 kHz and 1 MHz).

For normal data transfer SDA is allowed to change only during SCL low. Changes during SCL high are reserved for indicating the START and STOP conditions.

2.3 Serial Clock (SCL)

This input is used to synchronize the data transfer to and from the device.

2.4 Write Protect (WP)

This pin can be connected to either Vss, Vcc or left floating. Internal pull-down circuitry on this pin will keep the device in the unprotected state if left floating. If tied to Vss or left floating, normal memory operation is enabled (read/write the entire memory 0000-7FFF).

If tied to Vcc, WRITE operations are inhibited. Read operations are not affected.

3.0 FUNCTIONAL DESCRIPTION

The 24XX256 supports a bi-directional 2-wire bus and data transmission protocol. A device that sends data onto the bus is defined as a transmitter and a device receiving data as a receiver. The bus must be controlled by a master device which generates the serial clock (SCL), controls the bus access, and generates the START and STOP conditions while the 24XX256 works as a slave. Both master and slave can operate as a transmitter or receiver, but the master device determines which mode is activated.

24AA256/24LC256/24FC256

4.0 BUS CHARACTERISTICS

The following **bus protocol** has been defined:

- Data transfer may be initiated only when the bus is not busy.
- During data transfer, the data line must remain stable whenever the clock line is HIGH. Changes in the data line while the clock line is HIGH will be interpreted as a START or STOP condition.

Accordingly, the following bus conditions have been defined (Figure 4-1).

4.1 Bus not Busy (A)

Both data and clock lines remain HIGH.

4.2 Start Data Transfer (B)

A HIGH to LOW transition of the SDA line while the clock (SCL) is HIGH determines a START condition. All commands must be preceded by a START condition.

4.3 Stop Data Transfer (C)

A LOW to HIGH transition of the SDA line while the clock (SCL) is HIGH determines a STOP condition. All operations must end with a STOP condition.

4.4 Data Valid (D)

The state of the data line represents valid data when, after a START condition, the data line is stable for the duration of the HIGH period of the clock signal.

The data on the line must be changed during the LOW period of the clock signal. There is one bit of data per clock pulse.

Each data transfer is initiated with a START condition and terminated with a STOP condition. The number of the data bytes transferred between the START and STOP conditions is determined by the master device.

4.5 Acknowledge

Each receiving device, when addressed, is obliged to generate an acknowledge signal after the reception of each byte. The master device must generate an extra clock pulse which is associated with this acknowledge bit.

Note: The 24XX256 does not generate any acknowledge bits if an internal programming cycle is in progress.

A device that acknowledges must pull down the SDA line during the acknowledge clock pulse in such a way that the SDA line is stable LOW during the HIGH period of the acknowledge related clock pulse. Of course, setup and hold times must be taken into account. During reads, a master must signal an end of data to the slave by NOT generating an acknowledge bit on the last byte that has been clocked out of the slave. In this case, the slave (24XX256) will leave the data line HIGH to enable the master to generate the STOP condition.

FIGURE 4-1: DATA TRANSFER SEQUENCE ON THE SERIAL BUS

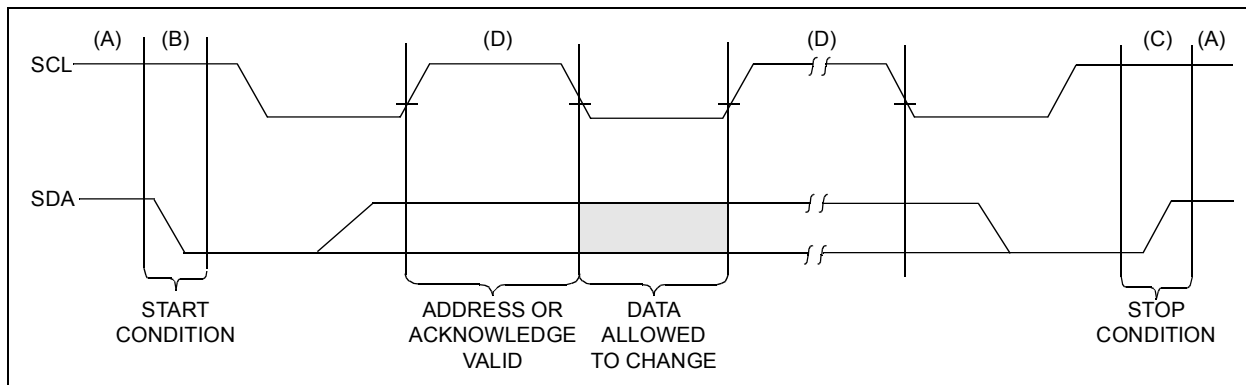
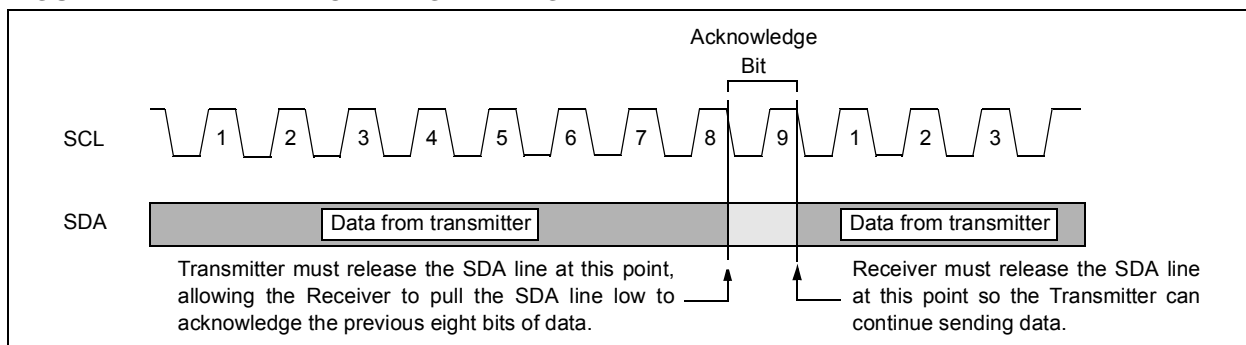

FIGURE 4-2: ACKNOWLEDGE TIMING



5.0 DEVICE ADDRESSING

A control byte is the first byte received following the start condition from the master device (Figure 5-1). The control byte consists of a 4-bit control code. For the 24XX256, this is set as 1010 binary for read and write operations. The next three bits of the control byte are the chip select bits (A2, A1, A0). The chip select bits allow the use of up to eight 24XX256 devices on the same bus and are used to select which device is accessed. The chip select bits in the control byte must correspond to the logic levels on the corresponding A2, A1 and A0 pins for the device to respond. These bits are, in effect, the three most significant bits of the word address.

For the MSOP package, the A0 and A1 pins are not connected. During device addressing, the A0 and A1 chip select bits (Figures 5-1 and 5-2) should be set to '0'. Only two 24XX256 MSOP packages can be connected to the same bus.

The last bit of the control byte defines the operation to be performed. When set to a one, a read operation is selected. When set to a zero, a write operation is selected. The next two bytes received define the address of the first data byte (Figure 5-2). Because only A14...A0 are used, the upper address bits are a don't care. The upper address bits are transferred first, followed by the less significant bits.

Following the start condition, the 24XX256 monitors the SDA bus checking the device type identifier being transmitted. Upon receiving a 1010 code and appropriate device select bits, the slave device outputs an acknowledge signal on the SDA line. Depending on the state of the R/W bit, the 24XX256 will select a read or write operation.

FIGURE 5-1: CONTROL BYTE FORMAT

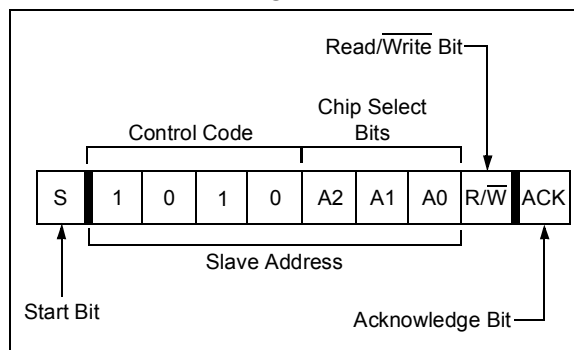

5.1 Contiguous Addressing Across Multiple Devices

The chip select bits A2, A1, A0 can be used to expand the contiguous address space for up to 2 Mbit by adding up to eight 24XX256s on the same bus. In this case, software can use A0 of the **control byte** as address bit A15; A1 as address bit A16; and A2 as address bit A17. It is not possible to sequentially read across device boundaries.

For the MSOP package, up to two 24XX256 devices can be added for up to 512 Kbit of address space. In this case, software can use A2 of the control byte as address bit A17. Bits A0 (A15) and A1 (A16) of the **control byte** must always be set to a logic '0' for the MSOP.

FIGURE 5-2: ADDRESS SEQUENCE BIT ASSIGNMENTS

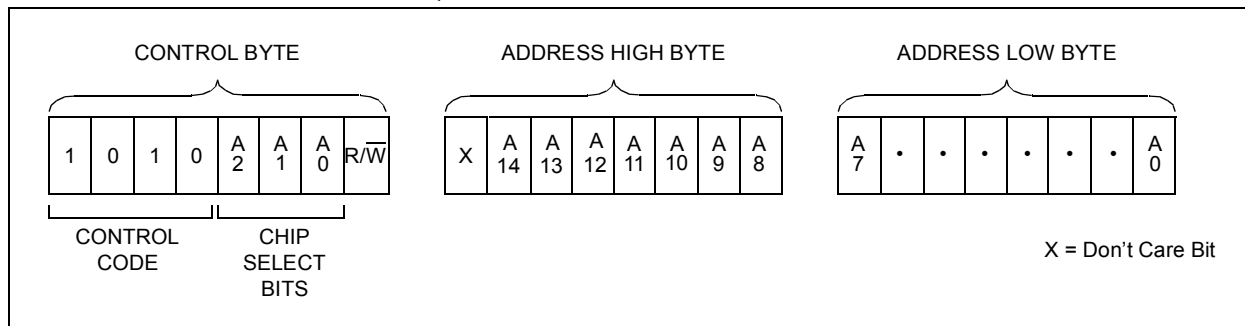

24AA256/24LC256/24FC256

6.0 WRITE OPERATIONS

6.1 Byte Write

Following the start condition from the master, the control code (four bits), the chip select (three bits) and the R/W bit (which is a logic low) are clocked onto the bus by the master transmitter. This indicates to the addressed slave receiver that the address high byte will follow after it has generated an acknowledge bit during the ninth clock cycle. Therefore, the next byte transmitted by the master is the high-order byte of the word address and will be written into the address pointer of the 24XX256. The next byte is the least significant address byte. After receiving another acknowledge signal from the 24XX256, the master device will transmit the data word to be written into the addressed memory location. The 24XX256 acknowledges again and the master generates a stop condition. This initiates the internal write cycle and during this time, the 24XX256 will not generate acknowledge signals (Figure 6-1). If an attempt is made to write to the array with the WP pin held high, the device will acknowledge the command but no write cycle will occur, no data will be written, and the device will immediately accept a new command. After a byte write command, the internal address counter will point to the address location following the one that was just written.

6.2 Page Write

The write control byte, word address and the first data byte are transmitted to the 24XX256 in much the same way as in a byte write. The exception is that instead of generating a stop condition, the master transmits up to 63 additional bytes, which are temporarily stored in the on-chip page buffer and will be written into memory once the master has transmitted a stop condition. Upon receipt of each word, the six lower address pointer bits are internally incremented by one. If the master should

transmit more than 64 bytes prior to generating the stop condition, the address counter will roll over and the previously received data will be overwritten. As with the byte write operation, once the stop condition is received, an internal write cycle will begin (Figure 6-2). If an attempt is made to write to the array with the WP pin held high, the device will acknowledge the command but no write cycle will occur, no data will be written and the device will immediately accept a new command.

6.3 Write Protection

The WP pin allows the user to write-protect the entire array (0000-7FFF) when the pin is tied to Vcc. If tied to Vss or left floating, the write protection is disabled. The WP pin is sampled at the STOP bit for every write command (Figure 1-1). Toggling the WP pin after the STOP bit will have no effect on the execution of the write cycle.

Note: Page write operations are limited to writing bytes within a single physical page, **regardless** of the number of bytes actually being written. Physical page boundaries start at addresses that are integer multiples of the page buffer size (or 'page size') and end at addresses that are integer multiples of [page size - 1]. If a page write command attempts to write across a physical page boundary, the result is that the data wraps around to the beginning of the current page (overwriting data previously stored there), instead of being written to the next page, as might be expected. It is, therefore, necessary for the application software to prevent page write operations that would attempt to cross a page boundary.

FIGURE 6-1: BYTE WRITE

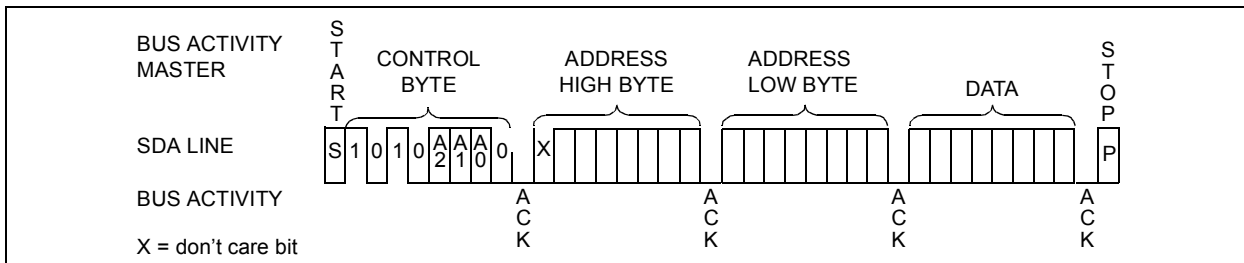
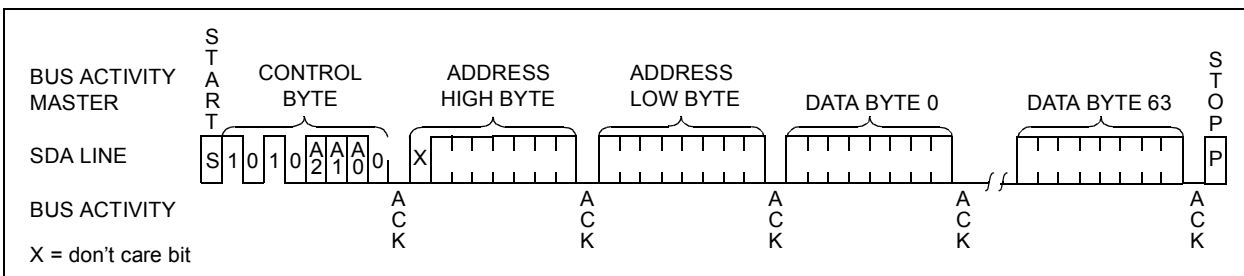

FIGURE 6-2: PAGE WRITE



7.0 ACKNOWLEDGE POLLING

Since the device will not acknowledge during a write cycle, this can be used to determine when the cycle is complete (This feature can be used to maximize bus throughput.) Once the stop condition for a write command has been issued from the master, the device initiates the internally timed write cycle. ACK polling can be initiated immediately. This involves the master sending a start condition, followed by the control byte for a write command ($R/\overline{W} = 0$). If the device is still busy with the write cycle, then no ACK will be returned. If no ACK is returned, the start bit and control byte must be resent. If the cycle is complete, then the device will return the ACK and the master can then proceed with the next read or write command. See Figure 7-1 for flow diagram.

FIGURE 7-1: ACKNOWLEDGE POLLING FLOW

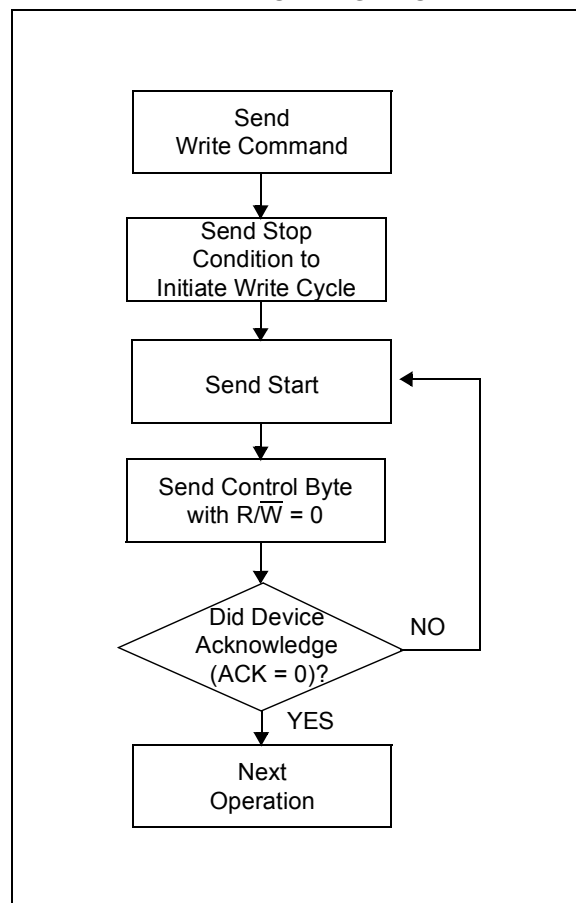

24AA256/24LC256/24FC256

8.0 READ OPERATION

Read operations are initiated in much the same way as write operations, with the exception that the $\overline{R/W}$ bit of the control byte is set to '1'. There are three basic types of read operations: current address read, random read and sequential read.

8.1 Current Address Read

The 24XX256 contains an address counter that maintains the address of the last word accessed, internally incremented by '1'. Therefore, if the previous read access was to address n (n is any legal address), the next current address read operation would access data from address n + 1.

Upon receipt of the control byte with $\overline{R/W}$ bit set to '1', the 24XX256 issues an acknowledge and transmits the 8-bit data word. The master will not acknowledge the transfer but does generate a stop condition and the 24XX256 discontinues transmission (Figure 8-1).

FIGURE 8-1: CURRENT ADDRESS READ

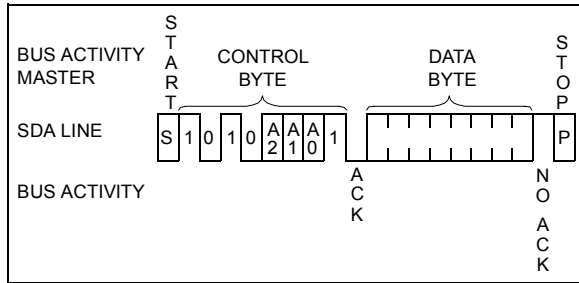

8.2 Random Read

Random read operations allow the master to access any memory location in a random manner. To perform this type of read operation, the word address must first be set. This is done by sending the word address to the 24XX256 as part of a write operation ($\overline{R/W}$ bit set to '0'). Once the word address is sent, the master generates a start condition following the acknowledge. This terminates the write operation, but not before the internal address pointer is set. The master then issues the control byte again but with the $\overline{R/W}$ bit set to a one. The 24XX256 will then issue an acknowledge and transmit the 8-bit data word. The master will not acknowledge the transfer, though it does generate a stop condition, which causes the 24XX256 to discontinue transmission (Figure 8-2). After a random read command, the internal address counter will point to the address location following the one that was just read.

8.3 Sequential Read

Sequential reads are initiated in the same way as a random read except that after the 24XX256 transmits the first data byte, the master issues an acknowledge as opposed to the stop condition used in a random read. This acknowledge directs the 24XX256 to transmit the next sequentially addressed 8-bit word (Figure 8-3). Following the final byte transmitted to the master, the master will NOT generate an acknowledge but will generate a stop condition. To provide sequential reads, the 24XX256 contains an internal address pointer which is incremented by one at the completion of each operation. This address pointer allows the entire memory contents to be serially read during one operation. The internal address pointer will automatically roll over from address 7FFF to address 0000 if the master acknowledges the byte received from the array address 7FFF.

FIGURE 8-2: RANDOM READ

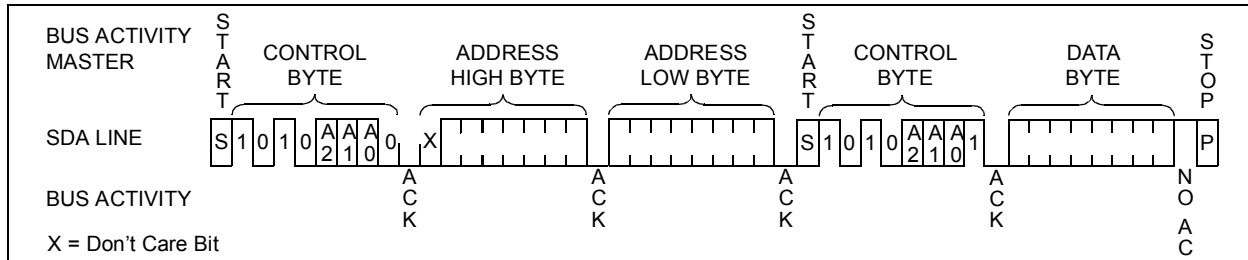
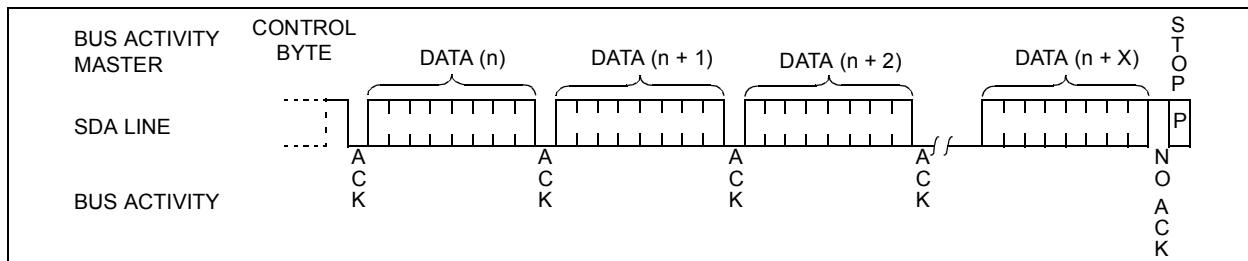

FIGURE 8-3: SEQUENTIAL READ



24AA256/24LC256/24FC256

9.0 PACKAGING INFORMATION

9.1 Package Marking Information

8-Lead PDIP (300 mil)

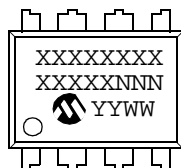

Example:

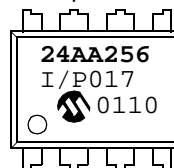

8-Lead SOIC (150 mil)

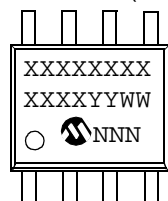

Example:

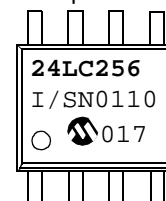

8-Lead SOIC (208 mil)

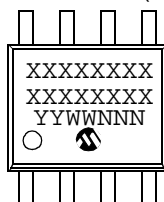

Example:

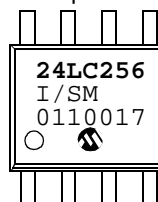

8-Lead TSSOP



Example:

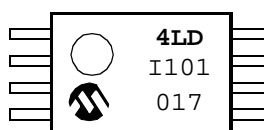

Legend:	XX...X	Customer specific information*
	Y	Year code (last digit of calendar year)
	YY	Year code (last 2 digits of calendar year)
	WW	Week code (week of January 1 is week '01')
	NNN	Alphanumeric traceability code

Note: In the event the full Microchip part number cannot be marked on one line, it will be carried over to the next line thus limiting the number of available characters for customer specific information.

* Standard device marking consists of Microchip part number, year code, week code, and traceability code. For device marking beyond this, certain price adders apply. Please check with your Microchip Sales Office.

24AA256/24LC256/24FC256

Package Marking Information (Continued)

8-Lead MSOP



Example:



8-Lead DFN

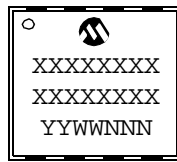

Example:



14-Lead TSSOP

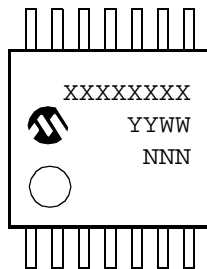

Example:

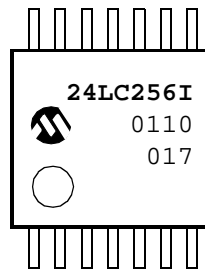

Legend:	XX...X	Customer specific information*
	Y	Year code (last digit of calendar year)
	YY	Year code (last 2 digits of calendar year)
	WW	Week code (week of January 1 is week '01')
	NNN	Alphanumeric traceability code
Note: In the event the full Microchip part number cannot be marked on one line, it will be carried over to the next line thus limiting the number of available characters for customer specific information.		

* Standard device marking consists of Microchip part number, year code, week code, and traceability code. For device marking beyond this, certain price adders apply. Please check with your Microchip Sales Office.

24AA256/24LC256/24FC256

8-Lead Plastic Dual In-line (P) – 300 mil (PDIP)

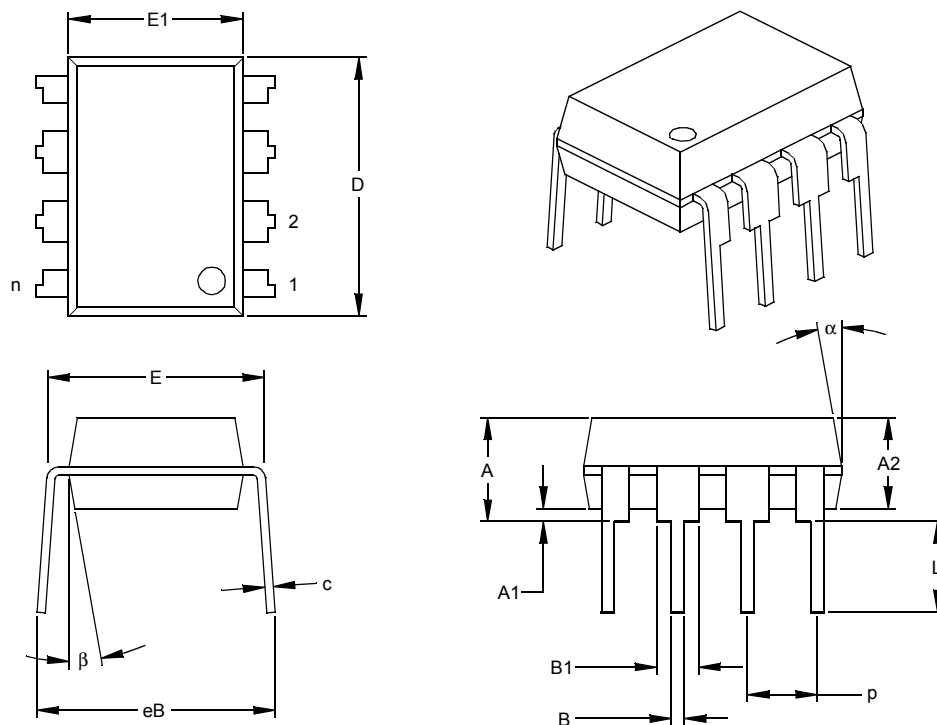

Dimension Limits	Units	INCHES*			MILLIMETERS		
		MIN	NOM	MAX	MIN	NOM	MAX
Number of Pins	n		8			8	
Pitch	p		.100			2.54	
Top to Seating Plane	A	.140	.155	.170	3.56	3.94	4.32
Molded Package Thickness	A2	.115	.130	.145	2.92	3.30	3.68
Base to Seating Plane	A1	.015			0.38		
Shoulder to Shoulder Width	E	.300	.313	.325	7.62	7.94	8.26
Molded Package Width	E1	.240	.250	.260	6.10	6.35	6.60
Overall Length	D	.360	.373	.385	9.14	9.46	9.78
Tip to Seating Plane	L	.125	.130	.135	3.18	3.30	3.43
Lead Thickness	c	.008	.012	.015	0.20	0.29	0.38
Upper Lead Width	B1	.045	.058	.070	1.14	1.46	1.78
Lower Lead Width	B	.014	.018	.022	0.36	0.46	0.56
Overall Row Spacing	§ eB	.310	.370	.430	7.87	9.40	10.92
Mold Draft Angle Top	α	5	10	15	5	10	15
Mold Draft Angle Bottom	β	5	10	15	5	10	15

* Controlling Parameter
 § Significant Characteristic

Notes:

Dimensions D and E1 do not include mold flash or protrusions. Mold flash or protrusions shall not exceed .010" (0.254mm) per side.
 JEDEC Equivalent: MS-001
 Drawing No. C04-018

24AA256/24LC256/24FC256

8-Lead Plastic Small Outline (SN) – Narrow, 150 mil (SOIC)

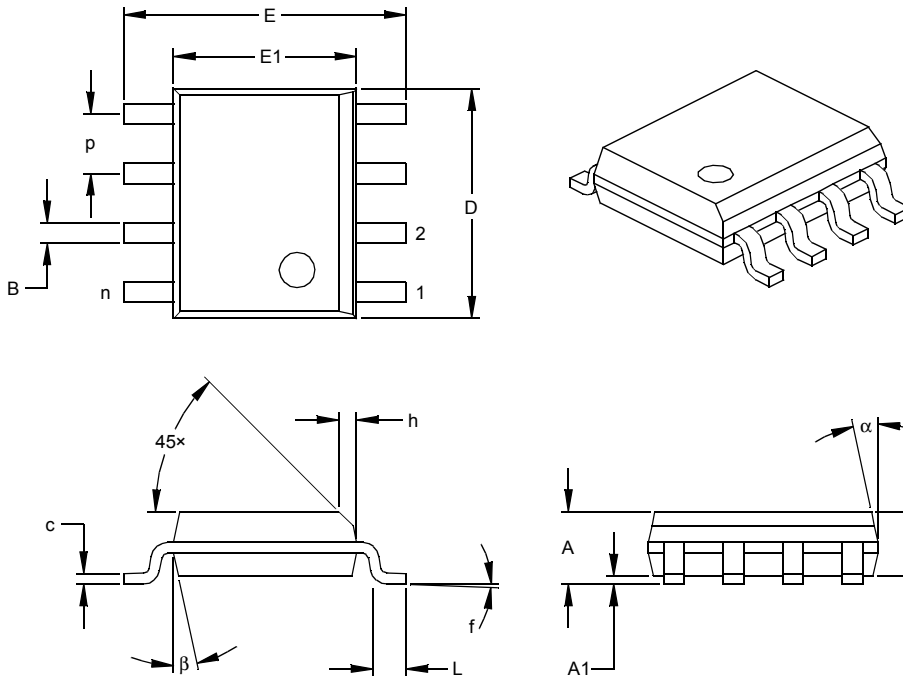

Units		INCHES*			MILLIMETERS		
Dimension Limits		MIN	NOM	MAX	MIN	NOM	MAX
Number of Pins	n		8			8	
Pitch	p		.050			1.27	
Overall Height	A	.053	.061	.069	1.35	1.55	1.75
Molded Package Thickness	A2	.052	.056	.061	1.32	1.42	1.55
Standoff §	A1	.004	.007	.010	0.10	0.18	0.25
Overall Width	E	.228	.237	.244	5.79	6.02	6.20
Molded Package Width	E1	.146	.154	.157	3.71	3.91	3.99
Overall Length	D	.189	.193	.197	4.80	4.90	5.00
Chamfer Distance	h	.010	.015	.020	0.25	0.38	0.51
Foot Length	L	.019	.025	.030	0.48	0.62	0.76
Foot Angle	f	0	4	8	0	4	8
Lead Thickness	c	.008	.009	.010	0.20	0.23	0.25
Lead Width	B	.013	.017	.020	0.33	0.42	0.51
Mold Draft Angle Top	α	0	12	15	0	12	15
Mold Draft Angle Bottom	β	0	12	15	0	12	15

* Controlling Parameter
 § Significant Characteristic

Notes:

Dimensions D and E1 do not include mold flash or protrusions. Mold flash or protrusions shall not exceed .010" (0.254mm) per side.
 JEDEC Equivalent: MS-012
 Drawing No. C04-057

24AA256/24LC256/24FC256

8-Lead Plastic Small Outline (SM) – Medium, 208 mil (SOIC)

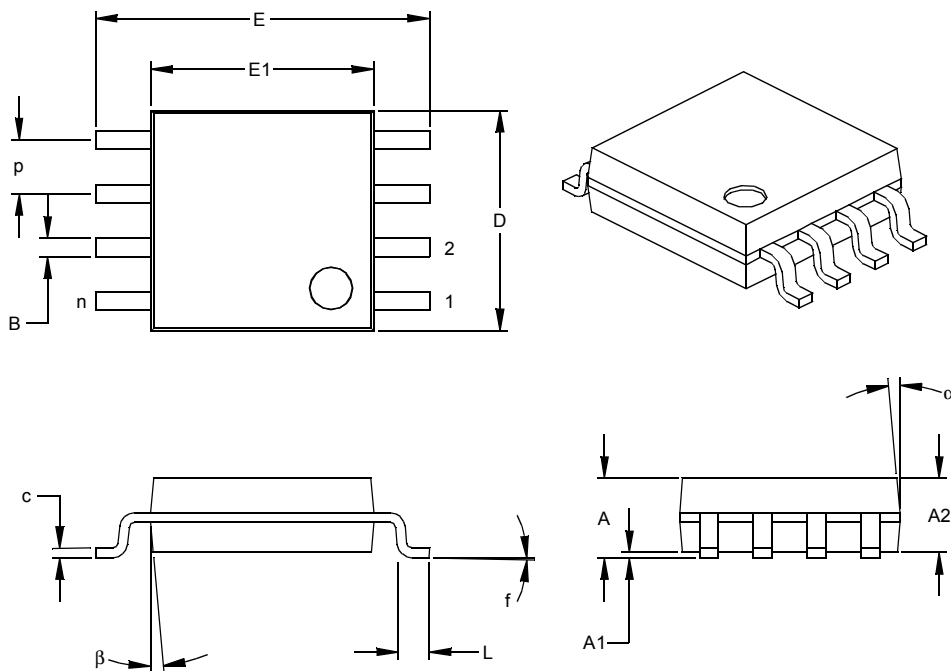

Units		INCHES*			MILLIMETERS		
Dimension Limits		MIN	NOM	MAX	MIN	NOM	MAX
Number of Pins	n		8			8	
Pitch	p		.050			1.27	
Overall Height	A	.070	.075	.080	1.78	1.97	2.03
Molded Package Thickness	A2	.069	.074	.078	1.75	1.88	1.98
Standoff §	A1	.002	.005	.010	0.05	0.13	0.25
Overall Width	E	.300	.313	.325	7.62	7.95	8.26
Molded Package Width	E1	.201	.208	.212	5.11	5.28	5.38
Overall Length	D	.202	.205	.210	5.13	5.21	5.33
Foot Length	L	.020	.025	.030	0.51	0.64	0.76
Foot Angle	f	0	4	8	0	4	8
Lead Thickness	c	.008	.009	.010	0.20	0.23	0.25
Lead Width	B	.014	.017	.020	0.36	0.43	0.51
Mold Draft Angle Top	α	0	12	15	0	12	15
Mold Draft Angle Bottom	β	0	12	15	0	12	15

* Controlling Parameter
 § Significant Characteristic

Notes:

Dimensions D and E1 do not include mold flash or protrusions. Mold flash or protrusions shall not exceed .010" (0.254mm) per side.

Drawing No. C04-056

24AA256/24LC256/24FC256

8-Lead Plastic Thin Shrink Small Outline (ST) – 4.4 mm (TSSOP)

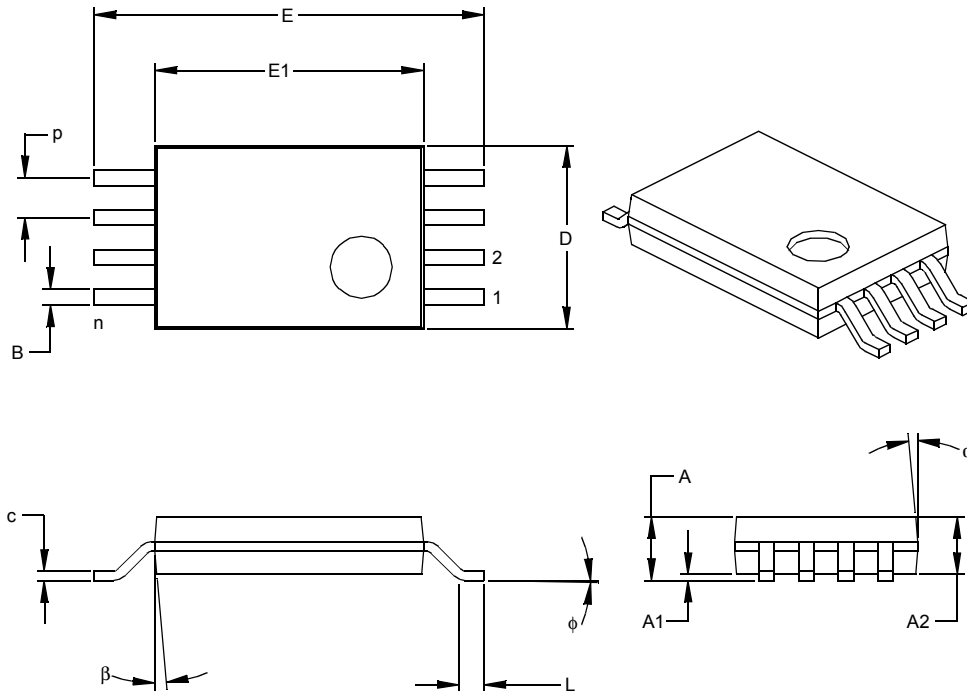

Dimension Limits	Units	INCHES			MILLIMETERS*		
	n	MIN	NOM	MAX	MIN	NOM	MAX
Number of Pins	n			8			8
Pitch	p		.026			0.65	
Overall Height	A			.043			1.10
Molded Package Thickness	A2	.033	.035	.037	0.85	0.90	0.95
Standoff §	A1	.002	.004	.006	0.05	0.10	0.15
Overall Width	E	.246	.251	.256	6.25	6.38	6.50
Molded Package Width	E1	.169	.173	.177	4.30	4.40	4.50
Molded Package Length	D	.114	.118	.122	2.90	3.00	3.10
Foot Length	L	.020	.024	.028	0.50	0.60	0.70
Foot Angle	ϕ	0	4	8	0	4	8
Lead Thickness	c	.004	.006	.008	0.09	0.15	0.20
Lead Width	B	.007	.010	.012	0.19	0.25	0.30
Mold Draft Angle Top	α	0	5	10	0	5	10
Mold Draft Angle Bottom	β	0	5	10	0	5	10

* Controlling Parameter
 § Significant Characteristic

Notes:

Dimensions D and E1 do not include mold flash or protrusions. Mold flash or protrusions shall not exceed .005" (0.127mm) per side.
 JEDEC Equivalent: MO-153
 Drawing No. C04-086

24AA256/24LC256/24FC256

8-Lead Plastic Micro Small Outline Package (MS) (MSOP)

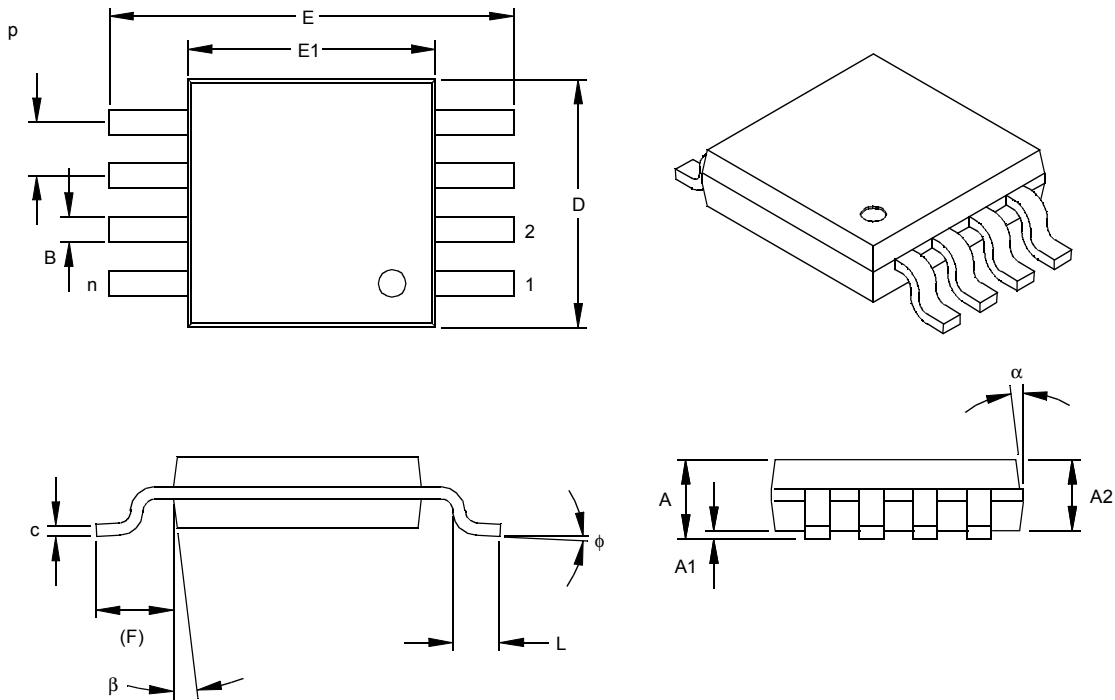

Units		INCHES			MILLIMETERS*		
Dimension Limits		MIN	NOM	MAX	MIN	NOM	MAX
Number of Pins	n		8				8
Pitch	P	.026			0.65		
Overall Height	A			.044			1.18
Molded Package Thickness	A2	.030	.034	.038	0.76	0.86	0.97
Standoff §	A1	.002		.006	0.05		0.15
Overall Width	E	.184	.193	.200	4.67	4.90	5.08
Molded Package Width	E1	.114	.118	.122	2.90	3.00	3.10
Overall Length	D	.114	.118	.122	2.90	3.00	3.10
Foot Length	L	.016	.022	.028	0.40	0.55	0.70
Footprint (Reference)	F	.035	.037	.039	0.90	0.95	1.00
Foot Angle	φ	0		6	0		6
Lead Thickness	c	.004	.006	.008	0.10	0.15	0.20
Lead Width	B	.010	.012	.016	0.25	0.30	0.40
Mold Draft Angle Top	α		7			7	
Mold Draft Angle Bottom	β		7			7	

*Controlling Parameter
 § Significant Characteristic

Notes:

Dimensions D and E1 do not include mold flash or protrusions. Mold flash or protrusions shall not exceed .010" (0.254mm) per side.

Drawing No. C04-111

24AA256/24LC256/24FC256

8-Lead Micro Leadframe Package (MF) 6x5 mm Body (DFN-S) (Formerly MLF-S)

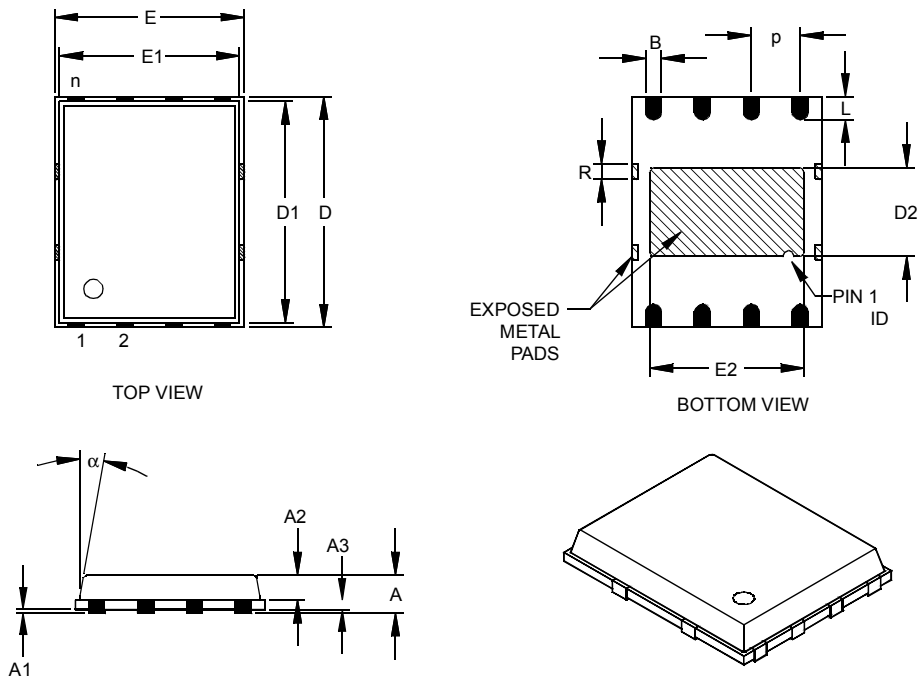

Dimension Limits	Units	INCHES			MILLIMETERS*		
		MIN	NOM	MAX	MIN	NOM	MAX
Number of Pins	n		8			8	
Pitch	P	.050 BSC			1.27 BSC		
Overall Height	A		.033	.039		0.85	1.00
Molded Package Thickness	A2		.026	.031		0.65	0.80
Standoff	A1	.000	.0004	.002	0.00	0.01	0.05
Base Thickness	A3	.008 REF.			0.20 REF.		
Overall Length	E	.194 BSC			4.92 BSC		
Molded Package Length	E1	.184 BSC			4.67 BSC		
Exposed Pad Length	E2	.152	.158	.163	3.85	4.00	4.15
Overall Width	D	.236 BSC			5.99 BSC		
Molded Package Width	D1	.226 BSC			5.74 BSC		
Exposed Pad Width	D2	.085	.091	.097	2.16	2.31	2.46
Lead Width	B	.014	.016	.019	0.35	0.40	0.47
Lead Length	L	.020	.024	.030	0.50	0.60	0.75
Tie Bar Width	R	.014			.356		
Mold Draft Angle Top	α				12°		

*Controlling Parameter

Notes:

Dimensions D and E1 do not include mold flash or protrusions. Mold flash or protrusions shall not exceed .010" (0.254mm) per side. JEDEC equivalent: pending

Drawing No. C04-113

24AA256/24LC256/24FC256

8-Lead Micro Leadframe Package (MF) 6x5 mm Body (DFN-S) (Continued)

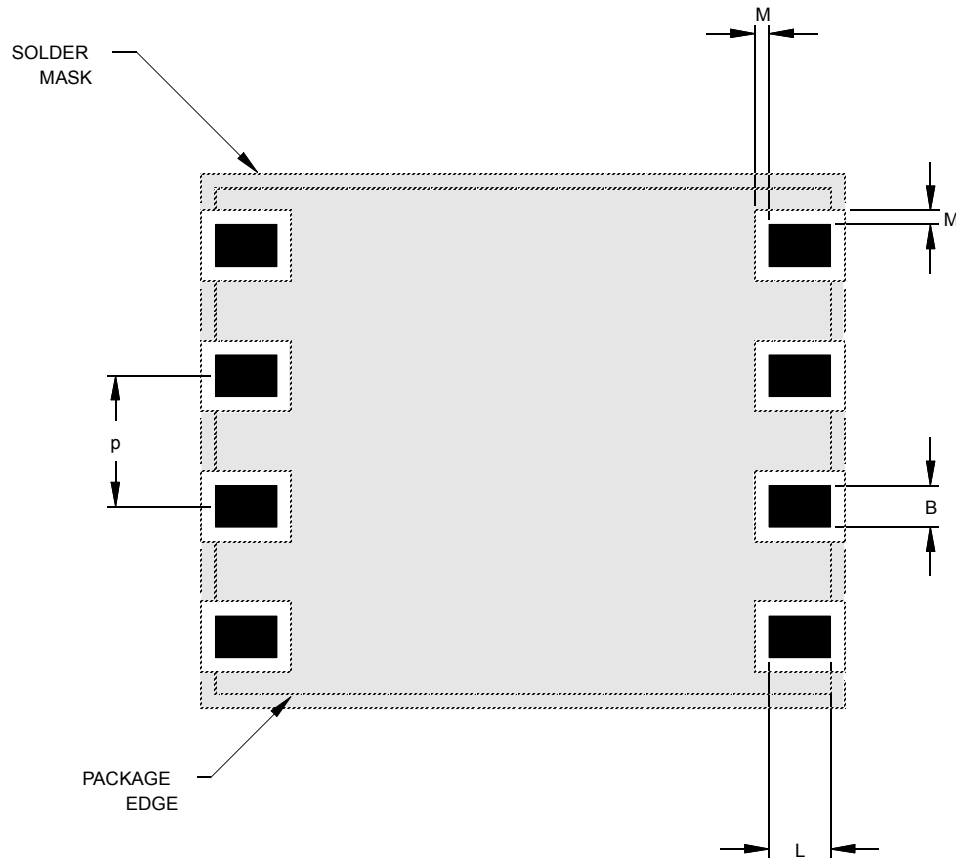

Units		INCHES			MILLIMETERS*		
Dimension Limits		MIN	NOM	MAX	MIN	NOM	MAX
Pitch	P	.050 BSC			1.27 BSC		
Pad Width	B	.014	.016	.019	0.35	0.40	0.47
Pad Length	L	.020	.024	.030	0.50	0.60	0.75
Pad to Solder Mask	M	.005		.006	0.13		0.15

*Controlling Parameter

Drawing No. C04-2113

24AA256/24LC256/24FC256

14-Lead Plastic Thin Shrink Small Outline (ST) – 4.4 mm (TSSOP)

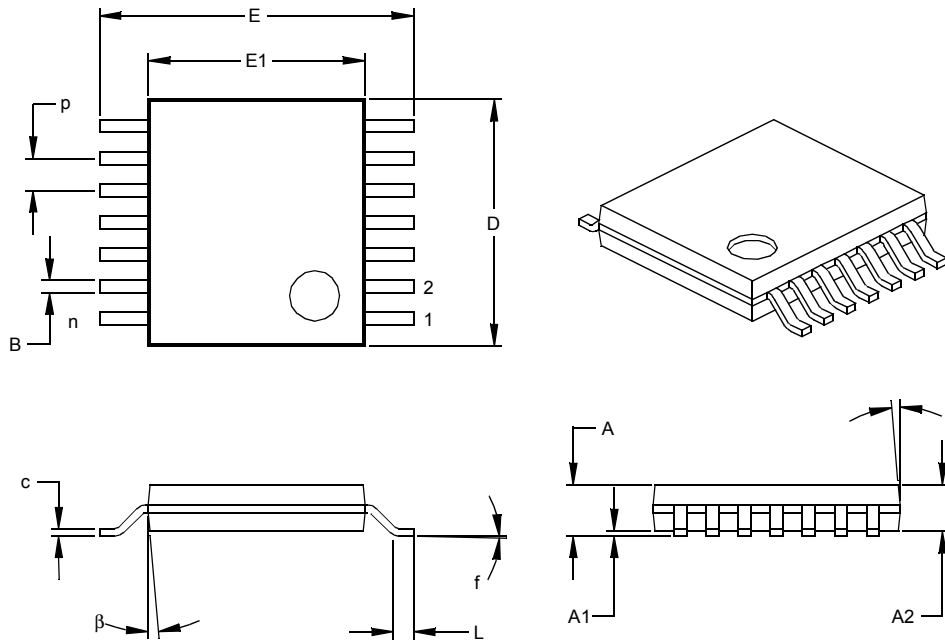

Dimension Limits	Units	INCHES			MILLIMETERS*		
		MIN	NOM	MAX	MIN	NOM	MAX
Number of Pins	n		14			14	
Pitch	p		.026			0.65	
Overall Height	A			.043			1.10
Molded Package Thickness	A2	.033	.035	.037	0.85	0.90	0.95
Standoff §	A1	.002	.004	.006	0.05	0.10	0.15
Overall Width	E	.246	.251	.256	6.25	6.38	6.50
Molded Package Width	E1	.169	.173	.177	4.30	4.40	4.50
Molded Package Length	D	.193	.197	.201	4.90	5.00	5.10
Foot Length	L	.020	.024	.028	0.50	0.60	0.70
Foot Angle	f	0	4	8	0	4	8
Lead Thickness	c	.004	.006	.008	0.09	0.15	0.20
Lead Width	B	.007	.010	.012	0.19	0.25	0.30
Mold Draft Angle Top	α	0	5	10	0	5	10
Mold Draft Angle Bottom	β	0	5	10	0	5	10

* Controlling Parameter
 § Significant Characteristic

Notes:
 Dimensions D and E1 do not include mold flash or protrusions. Mold flash or protrusions shall not exceed .005" (0.127mm) per side.
 JEDEC Equivalent: MO-153
 Drawing No. C04-087

ON-LINE SUPPORT

Microchip provides on-line support on the Microchip World Wide Web (WWW) site.

The web site is used by Microchip as a means to make files and information easily available to customers. To view the site, the user must have access to the Internet and a web browser, such as Netscape or Microsoft Explorer. Files are also available for FTP download from our FTP site.

Connecting to the Microchip Internet Web Site

The Microchip web site is available by using your favorite Internet browser to attach to:

www.microchip.com

The file transfer site is available by using an FTP service to connect to:

<ftp://ftp.microchip.com>

The web site and file transfer site provide a variety of services. Users may download files for the latest Development Tools, Data Sheets, Application Notes, User's Guides, Articles and Sample Programs. A variety of Microchip specific business information is also available, including listings of Microchip sales offices, distributors and factory representatives. Other data available for consideration is:

- Latest Microchip Press Releases
- Technical Support Section with Frequently Asked Questions
- Design Tips
- Device Errata
- Job Postings
- Microchip Consultant Program Member Listing
- Links to other useful web sites related to Microchip Products
- Conferences for products, Development Systems, technical information and more
- Listing of seminars and events

Systems Information and Upgrade Hot Line

The Systems Information and Upgrade Line provides system users a listing of the latest versions of all of Microchip's development systems software products. Plus, this line provides information on how customers can receive any currently available upgrade kits. The Hot Line Numbers are:

1-800-755-2345 for U.S. and most of Canada, and

1-480-792-7302 for the rest of the world.

013001

24AA256/24LC256/24FC256

READER RESPONSE

It is our intention to provide you with the best documentation possible to ensure successful use of your Microchip product. If you wish to provide your comments on organization, clarity, subject matter, and ways in which our documentation can better serve you, please FAX your comments to the Technical Publications Manager at (480) 792-4150.

Please list the following information, and use this outline to provide us with your comments about this Data Sheet.

To: Technical Publications Manager Total Pages Sent
RE: Reader Response
From: Name _____
Company _____
Address _____
City / State / ZIP / Country _____
Telephone: (_____) _____ - _____ FAX: (_____) _____ - _____

Application (optional):

Would you like a reply? ___Y ___N

Device: **24AA256/24LC256/24FC256** Literature Number: **DS21203J**

Questions:

1. What are the best features of this document?

2. How does this document meet your hardware and software development needs?

3. Do you find the organization of this data sheet easy to follow? If not, why?

4. What additions to the data sheet do you think would enhance the structure and subject?

5. What deletions from the data sheet could be made without affecting the overall usefulness?

6. Is there any incorrect or misleading information (what and where)?

7. How would you improve this document?

8. How would you improve our software, systems, and silicon products?

24AA256/24LC256/24FC256

PRODUCT IDENTIFICATION SYSTEM

To order or obtain information, e.g., on pricing or delivery, refer to the factory or the listed sales office.

<u>PART NO.</u>	<u>X</u>	<u>/XX</u>
Device	Temperature Range	Package
Device:	24AA256: 256 Kbit 1.8V I2C Serial EEPROM 24AA256T: 256 Kbit 1.8V I2C Serial EEPROM (Tape and Reel) 24LC256: 256 Kbit 2.5V I2C Serial EEPROM 24LC256T: 256 Kbit 2.5V I2C Serial EEPROM (Tape and Reel) 24FC256: 256 Kbit 1 MHz I2C Serial EEPROM 24FC256T: 256 Kbit 1 MHz I2C Serial EEPROM (Tape and Reel)	
Temperature Range:	I = -40°C to +85°C E = -40°C to +125°C	
Package:	P = Plastic DIP (300 mil body), 8-lead SN = Plastic SOIC (150 mil body), 8-lead SM = Plastic SOIC (208 mil body), 8-lead ST = Plastic TSSOP (4.4 mm), 8-lead ST14 = Plastic TSSOP (4.4 mm), 14-lead MF = Dual, Flat, No Lead (DFN)(6x5 mm body), 8-lead MS = Plastic Micro Small Outline (MSOP), 8-lead	

Examples:

- a) 24AA256-I/P: Industrial Temperature, PDIP package.
- b) 24AA256T-I/SN: Tape and Reel, Industrial Temp., SOIC package.
- c) 24AA256-I/ST: Industrial Temperature, TSSOP package.
- d) 24AA256-I/MS: Industrial Temperature, MSOP package.

- a) 24LC256-E/P: Extended Temperature, PDIP package.
- b) 24LC256-I/SN: Industrial Temperature, SOIC package.
- c) 24LC256T-I/SN: Tape and Reel, Industrial Temperature, SOIC package.
- d) 24LC256-I/MS: Industrial Temperature, MSOP package.

- a) 24FC256-I/P: Industrial Temperature, PDIP package.
- b) 24FC256-I/SN: Industrial Temperature, SOIC package.
- c) 24FC256T-I/SN: Tape and Reel, Industrial Temperature, SOIC package

Sales and Support

Data Sheets

Products supported by a preliminary Data Sheet may have an errata sheet describing minor operational differences and recommended workarounds. To determine if an errata sheet exists for a particular device, please contact one of the following:

1. Your local Microchip sales office
2. The Microchip Corporate Literature Center U.S. FAX: (480) 792-7277
3. The Microchip Worldwide Site (www.microchip.com)

Please specify which device, revision of silicon and Data Sheet (include Literature #) you are using.

New Customer Notification System

Register on our web site (www.microchip.com/cn) to receive the most current information on our products.

24AA256/24LC256/24FC256

NOTES:

24AA256/24LC256/24FC256

NOTES:

24AA256/24LC256/24FC256

NOTES:

Information contained in this publication regarding device applications and the like is intended through suggestion only and may be superseded by updates. It is your responsibility to ensure that your application meets with your specifications. No representation or warranty is given and no liability is assumed by Microchip Technology Incorporated with respect to the accuracy or use of such information, or infringement of patents or other intellectual property rights arising from such use or otherwise. Use of Microchip's products as critical components in life support systems is not authorized except with express written approval by Microchip. No licenses are conveyed, implicitly or otherwise, under any intellectual property rights.

Trademarks

The Microchip name and logo, the Microchip logo, FilterLab, KEELOQ, microID, MPLAB, PIC, PICmicro, PICMASTER, PICSTART, PRO MATE, SEEVAL and The Embedded Control Solutions Company are registered trademarks of Microchip Technology Incorporated in the U.S.A. and other countries.

dsPIC, ECONOMONITOR, FanSense, FlexROM, fuzzyLAB, In-Circuit Serial Programming, ICSP, ICEPIC, microPort, Migratable Memory, MPASM, MPLIB, MPLINK, MPSIM, MXDEV, MXLAB, PICC, PICDEM, PICDEM.net, rPIC, Select Mode and Total Endurance are trademarks of Microchip Technology Incorporated in the U.S.A.

Serialized Quick Turn Programming (SQTP) is a service mark of Microchip Technology Incorporated in the U.S.A.

All other trademarks mentioned herein are property of their respective companies.

© 2002, Microchip Technology Incorporated, Printed in the U.S.A., All Rights Reserved.

 Printed on recycled paper.

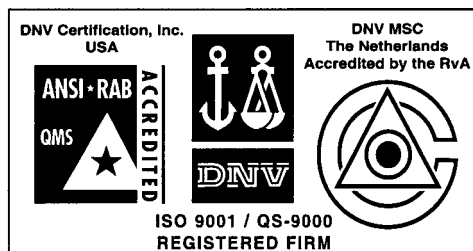

Microchip received QS-9000 quality system certification for its worldwide headquarters, design and wafer fabrication facilities in Chandler and Tempe, Arizona in July 1999 and Mountain View, California in March 2002. The Company's quality system processes and procedures are QS-9000 compliant for its PICmicro® 8-bit MCUs, KEELOQ® code hopping devices, Serial EEPROMs, microperipherals, non-volatile memory and analog products. In addition, Microchip's quality system for the design and manufacture of development systems is ISO 9001 certified.



MICROCHIP

WORLDWIDE SALES AND SERVICE

AMERICAS

Corporate Office

2355 West Chandler Blvd.
Chandler, AZ 85224-6199
Tel: 480-792-7200 Fax: 480-792-7277
Technical Support: 480-792-7627
Web Address: <http://www.microchip.com>

Rocky Mountain

2355 West Chandler Blvd.
Chandler, AZ 85224-6199
Tel: 480-692-7966 Fax: 480-792-4338

Atlanta

500 Sugar Mill Road, Suite 200B
Atlanta, GA 30350
Tel: 770-640-0034 Fax: 770-640-0307

Boston

2 Lan Drive, Suite 120
Westford, MA 01886
Tel: 978-692-3848 Fax: 978-692-3821

Chicago

333 Pierce Road, Suite 180
Itasca, IL 60143
Tel: 630-285-0071 Fax: 630-285-0075

Dallas

4570 Westgrove Drive, Suite 160
Addison, TX 75001
Tel: 972-818-7423 Fax: 972-818-2924

Detroit

Tri-Atria Office Building
32255 Northwestern Highway, Suite 190
Farmington Hills, MI 48334
Tel: 248-538-2250 Fax: 248-538-2260

Kokomo

2767 S. Albright Road
Kokomo, Indiana 46902
Tel: 765-864-8360 Fax: 765-864-8387

Los Angeles

18201 Von Karman, Suite 1090
Irvine, CA 92612
Tel: 949-263-1888 Fax: 949-263-1338

New York

150 Motor Parkway, Suite 202
Hauppauge, NY 11788
Tel: 631-273-5305 Fax: 631-273-5335

San Jose

Microchip Technology Inc.
2107 North First Street, Suite 590
San Jose, CA 95131
Tel: 408-436-7950 Fax: 408-436-7955

Toronto

6285 Northam Drive, Suite 108
Mississauga, Ontario L4V 1X5, Canada
Tel: 905-673-0699 Fax: 905-673-6509

ASIA/PACIFIC

Australia

Microchip Technology Australia Pty Ltd
Suite 22, 41 Rawson Street
Epping 2121, NSW
Australia
Tel: 61-2-9868-6733 Fax: 61-2-9868-6755

China - Beijing

Microchip Technology Consulting (Shanghai)
Co., Ltd., Beijing Liaison Office
Unit 915
Bei Hai Wan Tai Bldg.
No. 6 Chaoyangmen Beidajie
Beijing, 100027, No. China
Tel: 86-10-85282100 Fax: 86-10-85282104

China - Chengdu

Microchip Technology Consulting (Shanghai)
Co., Ltd., Chengdu Liaison Office
Rm. 2401, 24th Floor,
Ming Xing Financial Tower
No. 88 TIDU Street
Chengdu 610016, China
Tel: 86-28-86766200 Fax: 86-28-86766599

China - Fuzhou

Microchip Technology Consulting (Shanghai)
Co., Ltd., Fuzhou Liaison Office
Unit 28F, World Trade Plaza
No. 71 Wusi Road
Fuzhou 350001, China
Tel: 86-591-7503506 Fax: 86-591-7503521

China - Shanghai

Microchip Technology Consulting (Shanghai)
Co., Ltd.
Room 701, Bldg. B
Far East International Plaza
No. 317 Xian Xia Road
Shanghai, 200051
Tel: 86-21-6275-5700 Fax: 86-21-6275-5060

China - Shenzhen

Microchip Technology Consulting (Shanghai)
Co., Ltd., Shenzhen Liaison Office
Rm. 1315, 13/F, Shenzhen Kerry Centre,
Renminnan Lu
Shenzhen 518001, China
Tel: 86-755-2350361 Fax: 86-755-2366086

China - Hong Kong SAR

Microchip Technology Hongkong Ltd.
Unit 901-6, Tower 2, Metroplaza
223 Hing Fong Road
Kwai Fong, N.T., Hong Kong
Tel: 852-2401-1200 Fax: 852-2401-3431

India

Microchip Technology Inc.
India Liaison Office
Divyasree Chambers
1 Floor, Wing A (A3/A4)
No. 11, O'Shaughnessey Road
Bangalore, 560 025, India
Tel: 91-80-2290061 Fax: 91-80-2290062

Japan

Microchip Technology Japan K.K.
Benex S-1 6F
3-18-20, Shinyokohama
Kohoku-Ku, Yokohama-shi
Kanagawa, 222-0033, Japan
Tel: 81-45-471-6166 Fax: 81-45-471-6122

Korea

Microchip Technology Korea
168-1, Youngbo Bldg. 3 Floor
Samsung-Dong, Kangnam-Ku
Seoul, Korea 135-882
Tel: 82-2-554-7200 Fax: 82-2-558-5934

Singapore

Microchip Technology Singapore Pte Ltd.
200 Middle Road
#07-02 Prime Centre
Singapore, 188980
Tel: 65-6334-8870 Fax: 65-6334-8850

Taiwan

Microchip Technology (Barbados) Inc.,
Taiwan Branch
11F-3, No. 207
Tung Hua North Road
Taipei, 105, Taiwan
Tel: 886-2-2717-7175 Fax: 886-2-2545-0139

EUROPE

Denmark

Microchip Technology Nordic ApS
Regus Business Centre
Lautrup høj 1-3
Ballerup DK-2750 Denmark
Tel: 45 4420 9895 Fax: 45 4420 9910

France

Microchip Technology SARL
Parc d'Activite du Moulin de Massy
43 Rue du Saule Trapu
Batiment A - 1er Etage
91300 Massy, France
Tel: 33-1-69-53-63-20 Fax: 33-1-69-30-90-79

Germany

Microchip Technology GmbH
Gustav-Heinemann Ring 125
D-81739 Munich, Germany
Tel: 49-89-627-144 0 Fax: 49-89-627-144-44

Italy

Microchip Technology SRL
Centro Direzionale Colleoni
Palazzo Taurus 1 V. Le Colleoni 1
20041 Agrate Brianza
Milan, Italy
Tel: 39-039-65791-1 Fax: 39-039-6899883

United Kingdom

Microchip Ltd.
505 Eskdale Road
Winnersh Triangle
Wokingham
Berkshire, England RG41 5TU
Tel: 44 118 921 5869 Fax: 44-118 921-5820

Austria

Microchip Technology Austria GmbH
Durisolstrasse 2
A-4600 Wels
Austria
Tel: 43-7242-2244-399
Fax: 43-7242-2244-393

05/16/02